



WATKINS - JOHNSON COMPANY

440 Kings Village Road • Scotts Valley, California 95066 • (408) 438-2100
Microwave Device Products • Easylink 62602190
Production Equipment Products • Easylink 62887411

PROCUREMENT SPECIFICATION NO. 4902034-1
Watkins-Johnson Model 10C-87(H)
Controlled Atmosphere Conveyor Furnace

1.0 Scope This specification shall cover the manufacture of a controlled atmosphere conveyor furnace for operation to 1000 Degrees C in an atmosphere of air, hydrogen or nitrogen. The specification shall include all items necessary to deliver a complete furnace ready for installation and connection to utilities.

2.0 Specifications

2.1 Temperature The furnace shall be capable of continuous operation to 1000 Degrees C, except zone 1 shall be limited to 600 degrees C.

2.2 Muffle

2.2.1 Vertical Clearance A minimum vertical clearance of 2 inches shall be provided above the conveyor belt.

2.2.2 Heated Section A 11-1/2 inch wide by 4 inch high (inside dimensions) muffle of Type 330 Stainless Steel, or equal, shall be provided in the firing section. A sectioned channel-shaped hearth shall be provided in the firing section.

2.2.3 Cooling Section A 11-1/2 inch wide by 3 inch high (inside dimensions) by 72 inch long stainless steel muffle shall be provided in the cooling section. Heat exchange shall be through clamp-on water-cooled heat sinks. The cooling section shall be provided with a water temperature gauge and shall be capable of operating with either high- or low-pressure water systems. A panel-mounted flowmeter shall be provided.

- 2.3 Atmosphere The furnace shall be capable of utilizing air, nitrogen or hydrogen gas atmospheres within the muffle.
- 2.3.1 Atmosphere Inlet The furnace shall be supplied with atmosphere inlets located above the belt in the center of the heated section. Three flowmeters shall be provided; flowmeters shall be calibrated for hydrogen, air and nitrogen. A mixing chamber to blend hydrogen and nitrogen shall be provided.
- 2.3.2 Combustible Atmosphere Burnoff The furnace shall be provided with atmosphere exhaust burnoffs located at the entry and exit of the heated section and in the cooling section.
- 2.3.3 Cooling Shower An air, nitrogen or hydrogen cooling shower shall be provided in the cooling section. The cooling shower shall be provided with flowmeters calibrated for the three gasses mentioned above.
- 2.3.4 Curtain Assemblies The furnace shall be provided with a 36-inch flapper door assembly at each end of the furnace. Each flapper door assembly shall be provided with flowmeters calibrated for air and nitrogen. Gas purge in the curtain assemblies shall be from both above and below the belt.
- 2.3.5 Safety Shields Bolt-on type blast gates shall be provided at each end of the muffle.
- 2.3.6 Sampleports The furnace shall be provided with three sample ports near the bottom of the muffle and two for the incoming gases. Sample ports will be connected to the analyzer.
- 2.4 Conveyor System
- 2.4.1 Conveyor Belt The furnace shall be provided with a 10 inch wide conveyor belt of Incoloy 800 alloy (mesh 48-40-17-18).

2.4.2 Conveyor Speed The furnace shall be provided with a variable speed conveyor drive system capable of control between 2 to 30 inches per minute. Tachometer feedback closed loop control shall be provided. Speed control accuracy shall be $\pm 1/4\%$ over the full range.

NOTE: Design belt speed shall be 5 inches-per-minute.

2.4.3 Drive System The conveyor drive system shall provide positive traction and belt alignment throughout the furnace and shall be controlled through a dc motor. A reverse direction switch shall be mounted on the control panel.

2.4.4 Conveyor Belt Return The conveyor belt return shall be a roller conveyor.

2.4.5 Belt Cleaner A single brush type belt cleaner shall be provided.

2.5 Furnace Chamber The furnace chamber shall be divided into the following sections:

Entry 40 inches

Heated Section

Zone 1	19-1/4 inches
Zone 2	19-1/4 inches
Zone 3	19-1/4 inches
Zone 4	19-1/4 inches
Zone 5	9-5/8 inches

Total Heated Length 87 inches

Cooling Section

Insulated Pre-Cooling	12 inches
Water Cooling	72 inches

2.6 Temperature/Power Controls

2.6.1 Thermocouples Two Chromel/Alumel (Type K) thermocouples shall be provided in each independently controlled heated zone. Thermocouples shall be spring loaded under the muffle and shall be removable from the bottom of the furnace.

2.6.2 Process Controller The furnace shall be provided with a WJ-988 multi-channel microprocessor-based temperature controller. The controller shall provide three mode temperature control with keyboard entry of setpoint, power level, proportional band, rate, reset and high-low process alarm settings for each individual zone. Belt speed control shall be accomplished through the Model WJ-988 Microprocessor Controller. Up to eight different profiles (recipes) can be stored and recalled through the keyboard. An alphanumeric one line readout is provided for belt speed, temperature, setpoint, power level, proportional band, reset, rate and high-low process alarm settings for each zone.

2.6.3 Power Controls Power to the heating elements shall be controlled through zero firing optically isolated SCR power controllers.

2.6.4 Trim Controls Separate potentiometers shall be provided to adjust power levels to top and bottom elements relative to the side elements (side-to-center trim).

2.6.5 Temperature Recorder The furnace shall be supplied with a chessel model 301 chart recorder.

2.6.6 Printer The furnace shall be provided with an okidata on-line printer.

2.6.7 Function Controls The furnace shall be provided with switches and indicator lights for the following functions:

Control Power	Element Power
Conveyor System	Alarm Silence
Water Fail	Atmosphere System

2.7 Heating Elements The furnace shall be provided with heating elements of Kanthal A-1 alloy, or equal. Elements shall be supported in grooved ceramic backplates.

- 2.8 Safety Features The furnace shall be provided with the following safety features:
- 2.8.1 Thermocouple Break Protection Thermocouple break protection shall be provided on the temperature controller.
 - 2.8.2 Water Failure A flow switch shall be provided to shut off conveyor and element power in the event of water failure.
 - 2.8.3 Atmosphere Safety The furnace shall comply with Motorola Safety Specification No. 118.
 - 2.8.4 Overtemperature Protection The furnace shall be provided with a WJ-991 seven zone overtemperature scanning system.

3.0 Construction

- 3.1 Frame The furnace shall be constructed on a welded steel frame. Leveling capability of $\pm 1\text{-}1/2$ inches shall be provided.
- 3.2 Panels The furnace shall be enclosed with removable painted metal panels. Panels shall be painted Polane Korean Beige #63-H-197.
- 3.3 Insulation A suitably rated combination of insulating firebrick and batt-type insulating material shall enclose the heated section of the muffle.
- 3.4 Load/Unload Tables A 66 inch long load table with 36 inches of exposed belt and a 54 inch long unload table with 27 inches of exposed belt shall be provided. The table tops shall be of Type 304 Stainless Steel. A florescent light canopy shall be provided 14 inches above the load table and 36 inches above the unload table. The canopy shall cover the entire length of the tables. Static ground connectors shall also be provided on the table tops on both the left and right hand sides.

3.5 Weight and Dimensions

Overall dimensions	27.6 feet long 42 inches wide (46 inches at the control console) 50 inches high
Conveyor belt height	33 inches above floor level
Shipping weight	10,000 pounds

NOTE: All weight and dimensions in this specification are approximate. The furnace shall break down into sections not greater than 15 feet for shipping. (Frame break is optional.)

4.0 Utilities

4.1 Electrical Power Supply 50 KVA maximum connected load, 440/480 volts, three-phase, 60 Hz. The furnace shall be provided with a fused disconnect switch.

4.2 Atmosphere Air, Hydrogen and nitrogen at 20 psig plumbed to 3/8 inch pipe couplings.

Nitrogen	1000 scfh
Hydrogen	400 scfh
Air	1000 scfh

4.3 Water Supply 240 gph (minimum) at 60 psig.

4.4 Utility Connections Electrical power, atmosphere inlet and water connections shall be located at the top back side of the control console.

NOTE: Supply requirements in Paragraph 4.0 are recommended supplies and may exceed actual furnace requirements.

5.0 Documentation Two sets of Installation, Operation and Maintenance Manuals shall be provided.

ZONE		REV.	DESCRIPTION	DATE	APPROVED
		-	P.R. PER W.O.	8/1/89	RG

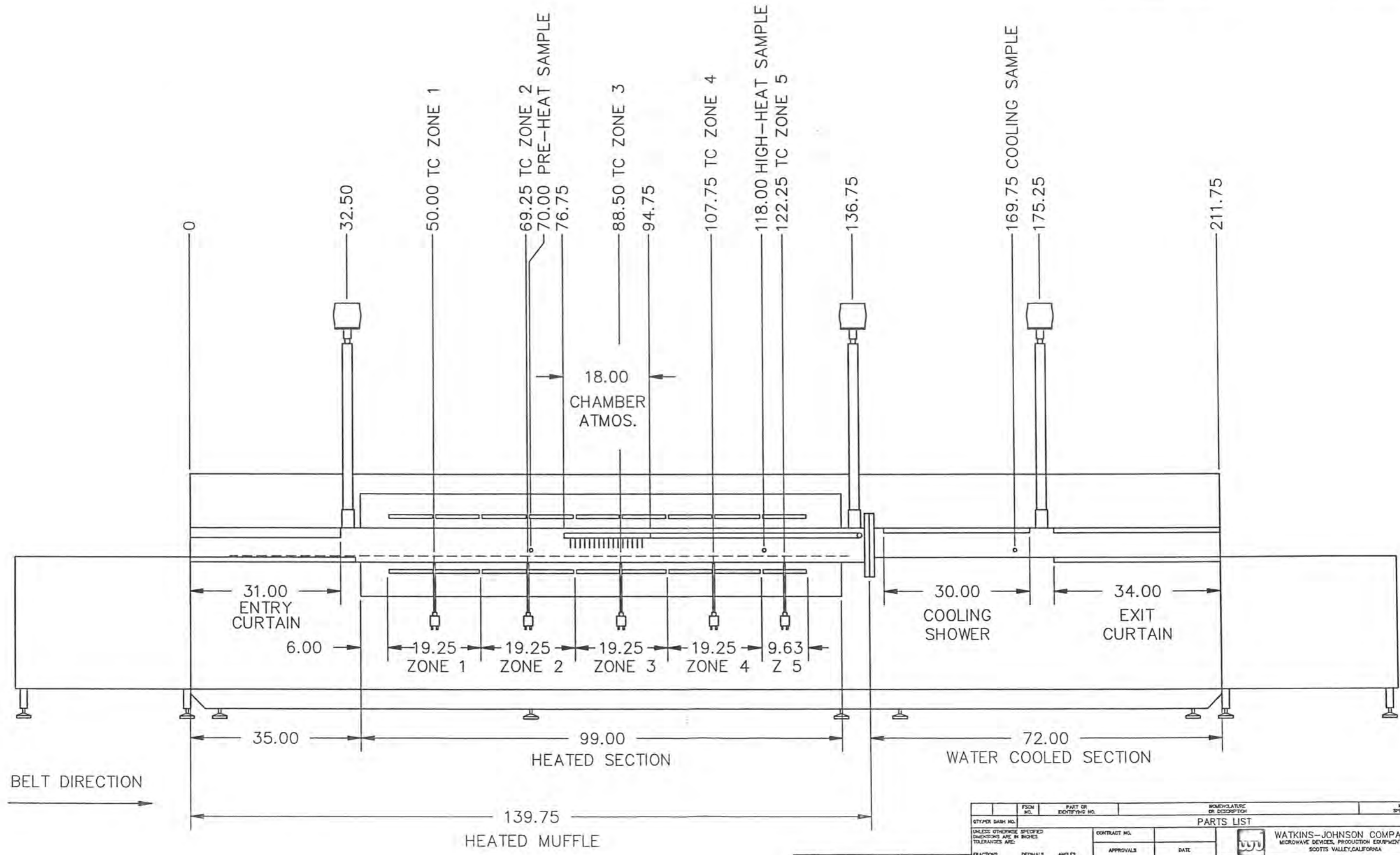

001	B902534	10C-87H
001	B901169	10C-87H
DASH NO.	NEXT ASSY	USED ON
	UNCTRL DSK NO.	

QTY/PER DASH NO.	FROM NO.	PART OR IDENTIFYING NO.	MANUFACTURE OR DESCRIPTION	MATERIAL SPECIFICATION	ITEM NO.
PARTS LIST					
UNLESS OTHERWISE SPECIFIED DIMENSIONS ARE IN INCHES TOLERANCES ARE:			CONTRACT NO.		
FRACTIONS 1/32	DECIMALS .005 & .010	ANGLES .005	APPROVALS	DATE	
FRESH			RG	8/1/89	
APPLICATION			CHECKED	DATE	
		DO NOT SCALE DRAWING	HG	8-23-89	
			ENGR.		
			MFG ENGR.		
			P.J.A.		
			SIZE	FROM NO.	DWG NO.
			D	05783	902536
			PLOTTING SCALE	BY	SHEET
			1=10	23	1 OF 1

WATKINS-JOHNSON COMPANY
 MICROWAVE DEVICES, PRODUCTION EQUIPMENT
 SCOTT'S VALLEY, CALIFORNIA
10C-87H FURNACE
ZONE LAYOUT

REVISIONS				
ZONE	REV.	DESCRIPTION	DATE	APPROVED
-	P.R.	PER W.O.	8/2/89	RG

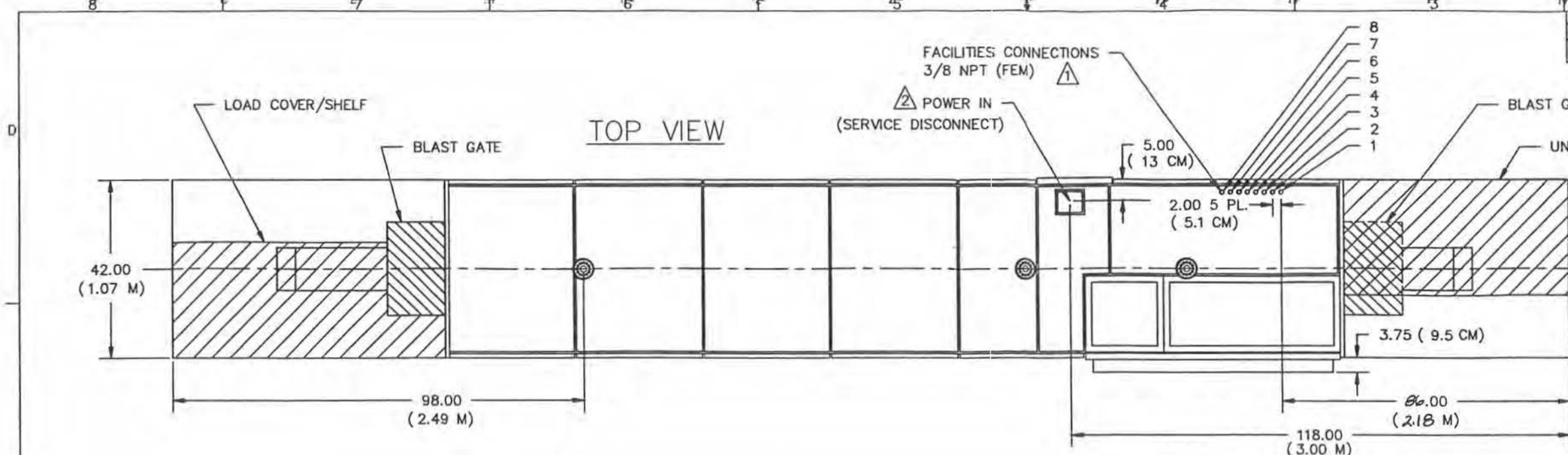

- NOTES:**
- △ FACILITIES REQUIREMENTS**
1. WATER OUT
 2. WATER IN - 120 GPH (MAX) @ 60 PSIG
 3. N2 - 34 SCFM (MAX) @ 20 PSIG
 4. AUX. N2 - 200 CU. FT. @ 20 PSIG (SEPARATE BOTTLE SUPPLY)
 5. H2 - 400 SCFH (MAX) @ 20 PSIG
 6. VENTURI N2 - 6 SCFM (MAX) @ 20 PSIG
 7. CLEAN DRY AIR - 18 SCFM (MAX) @ 20 PSIG
 8. FORMING GAS - 12 SCFM (MAX) @ 20 PSIG
- △ ELECTRICAL REQUIREMENTS**
- 480 VOLTS, 60 Hz, 3 PHASE
35 KVA MAX, 10 KVA TYP

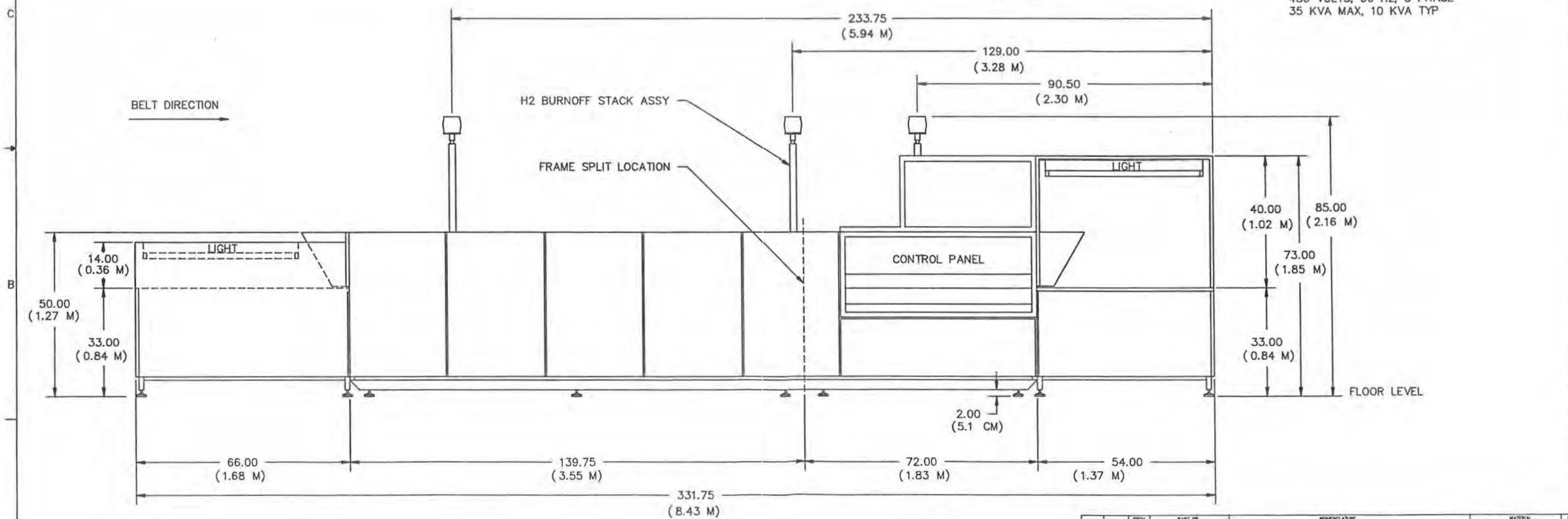

PARTS LIST		APPROVALS		DATE	
001	B902534	10C-87(H)	RG	8/2/89	
DASH NO.	NEXT ASSY	USED ON	CHECKED	DATE	
			HG	9.8.89	
APPLICATION		UNCTRL DSK NO.	DO NOT SCALE DRAWING		
WATKINS-JOHNSON COMPANY MICROWAVE DEVICES, PRODUCTION EQUIPMENT SCOTT'S VALLEY, CALIFORNIA		FURNACE OUTLINE & UTILITY CONNECTIONS			
SIZE	FROM NO.	DWG NO.	REV.		
D	05783	902535	-		
PLOTING SCALE		BY	SHEET		
1=15		23	1 OF 1		

DWG. NO.		REV.	DESCRIPTION	DATE	APPROVED
= PR PER W.O.#					

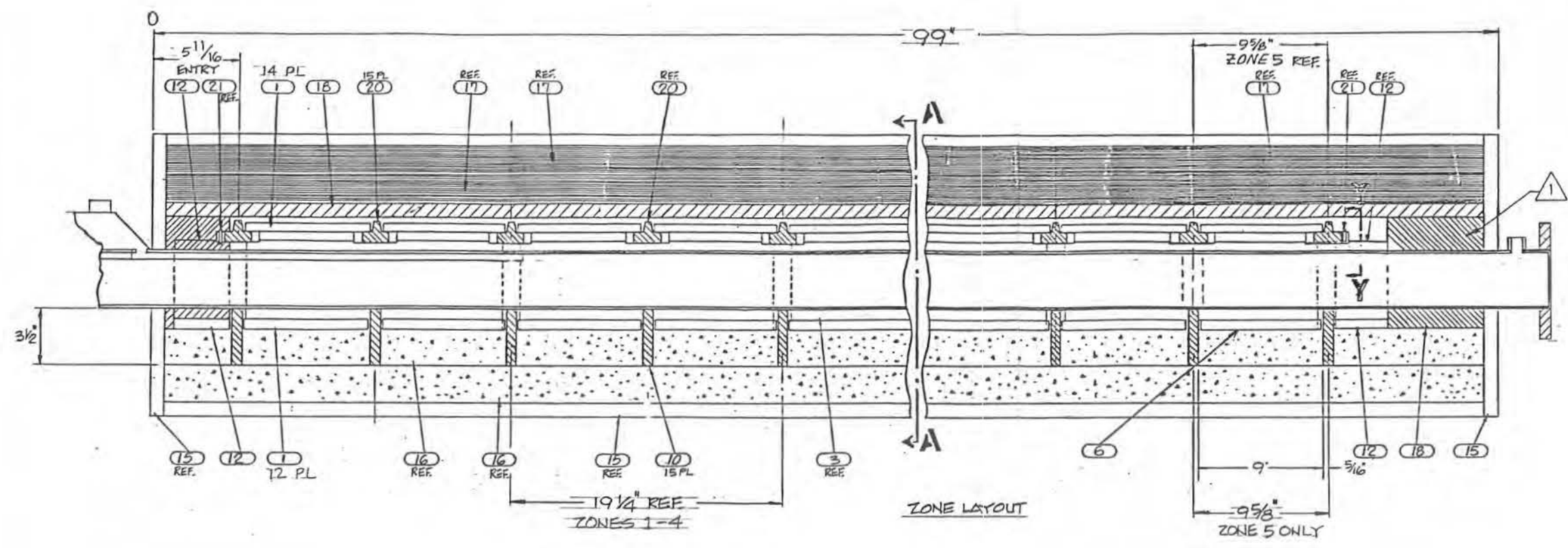

NOTES:
 1 PACK BOTH ENDS WITH CERAFELT, SIDES, TOP, & BOTTOM

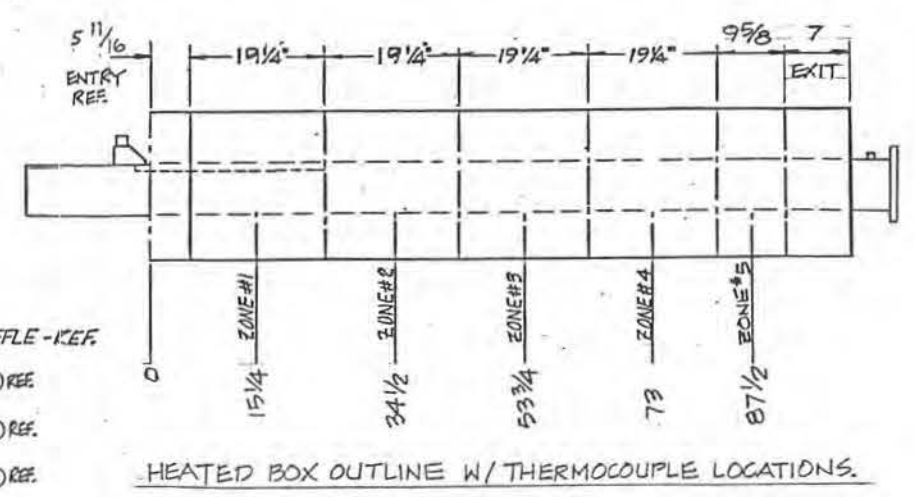
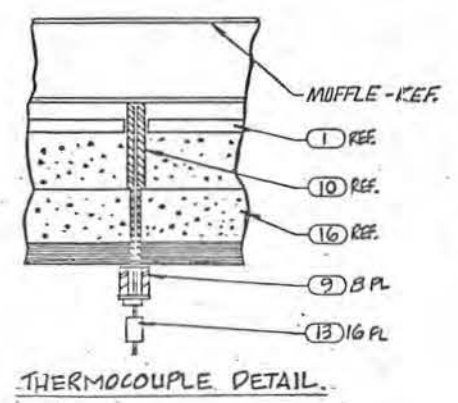
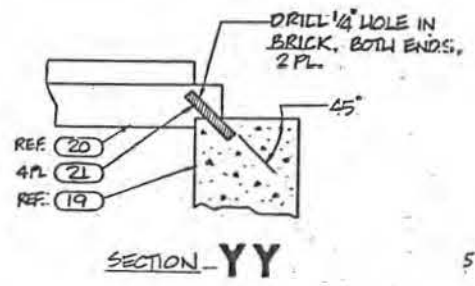
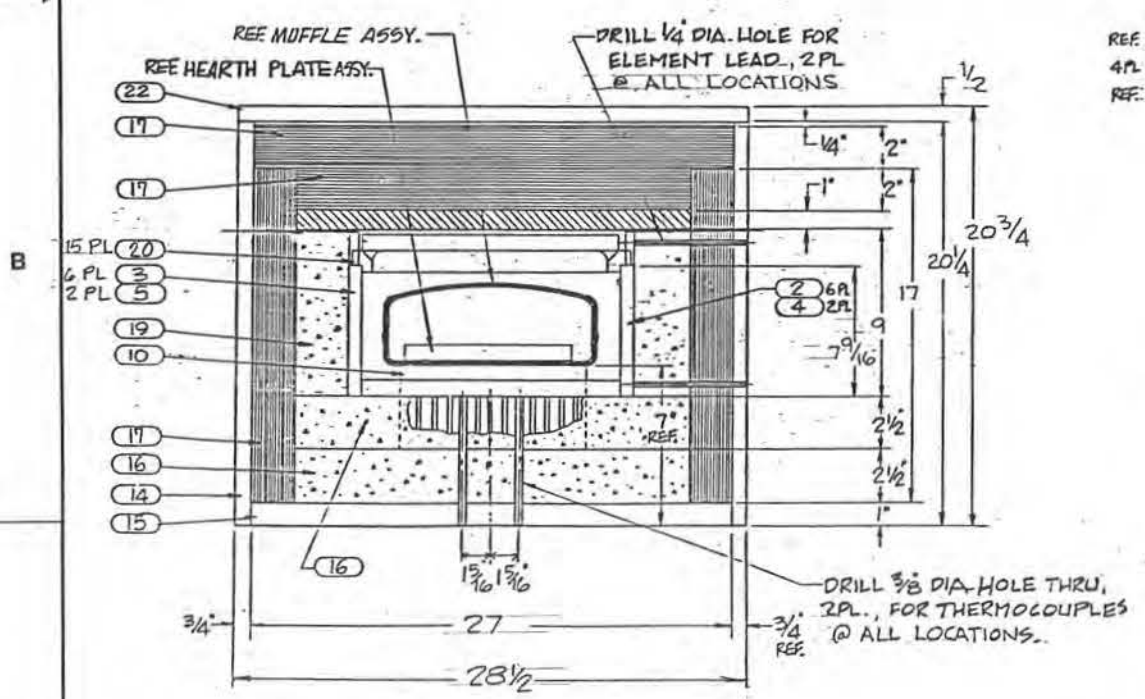

SEE B902555, SHT. 1 OF 2, FOR PARTS LIST.

001		PART OR IDENTIFYING NO.		NOMENCLATURE OR DESCRIPTION		MATERIAL SPECIFICATION		ITEM NO.	
QTY PER DASH NO.		CONTRACT NO.		PARTS LIST		WATKINS-JOHNSON COMPANY MICROWAVE DEVICES, PRODUCTION EQUIPMENT SCOTTS VALLEY, CALIFORNIA			
UNLESS OTHERWISE SPECIFIED DIMENSIONS ARE IN INCHES TOLERANCES ARE: FRACTIONS DECIMALS ANGLES ± 1/32 ± .005 ± .005 ± .005		APPROVALS		DATE		DRAWN R6		8/3/89	
MATERIAL		CHECKED		ENGR.		MFG. ENGR.		P.A.	
FINISH		SCALE		DWG. NO.		902555		REV. -	
DASH NO.		NEXT ASSY.		USED ON		SIZE D		FSCM NO. 05783	
APPLICATION		DO NOT SCALE DRAWING		DWG. NO. 902555		DIV 23		SHEET 2 OF 2	