

# AMI PRESCO CP436 Table Top Screen Printer

Type: Contact / off – contact

Squeegee Drive: Hydraulic

Screen Size: 5 x 5, 5 x 7, 8 x 7, 8 x 10"

Maximum Print Area: 3.5 x 4"

Maximum Substrate Size: 4.5 x 6"

X, Y and Z Adjust: 1" range

Rotary Adjust: 10 degree range

Squeegee Speed: 0 – 12.5 ips

Squeegee Pressure: Calibrated Springs

Carriage Repeatability: +- .0005

Squeegee Holder: 3" or 5.5 " Specify

Net Weight: 440 lbs

Services required: Air [dry] 80 psig, cfm

Electric: 115V, 50/60Hz, 5Amp

Vacuum: 25" HG, 4cfm

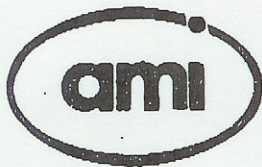
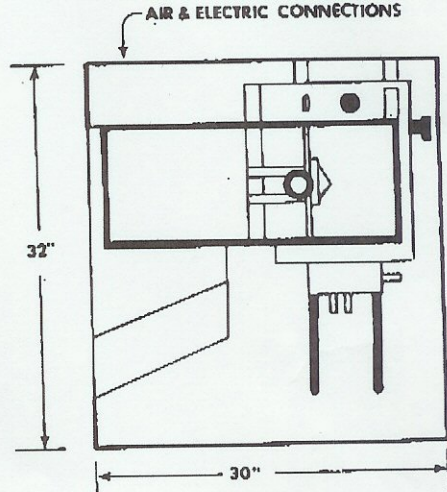
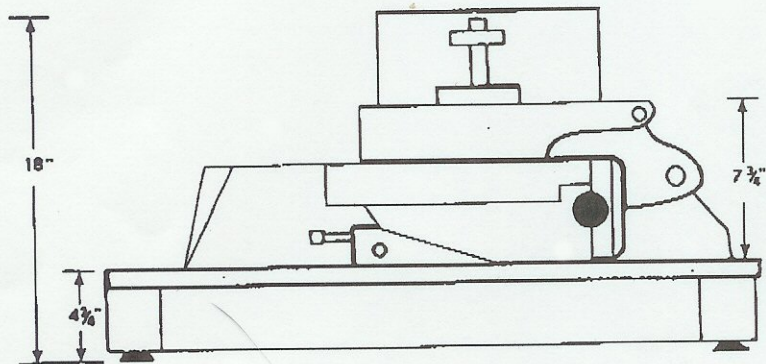

**affiliated  
manufacturers,  
inc.**

U.S. Route 22, P.O. Box 5049, North Branch, New Jersey 08876 - (201) 722-7100 TWX (710) 480-9234

PRESCO is a registered trademark of Affiliated Manufacturers, Inc.  
Design features and specifications subject to change without notice.

432-4/80-1  
Printed in U.S.A.